

TWO ROW - CABLE-TO-BOARD HORIZONTAL SMT

NM & NK

0.025" | 9 THROUGH 91 CONTACTS

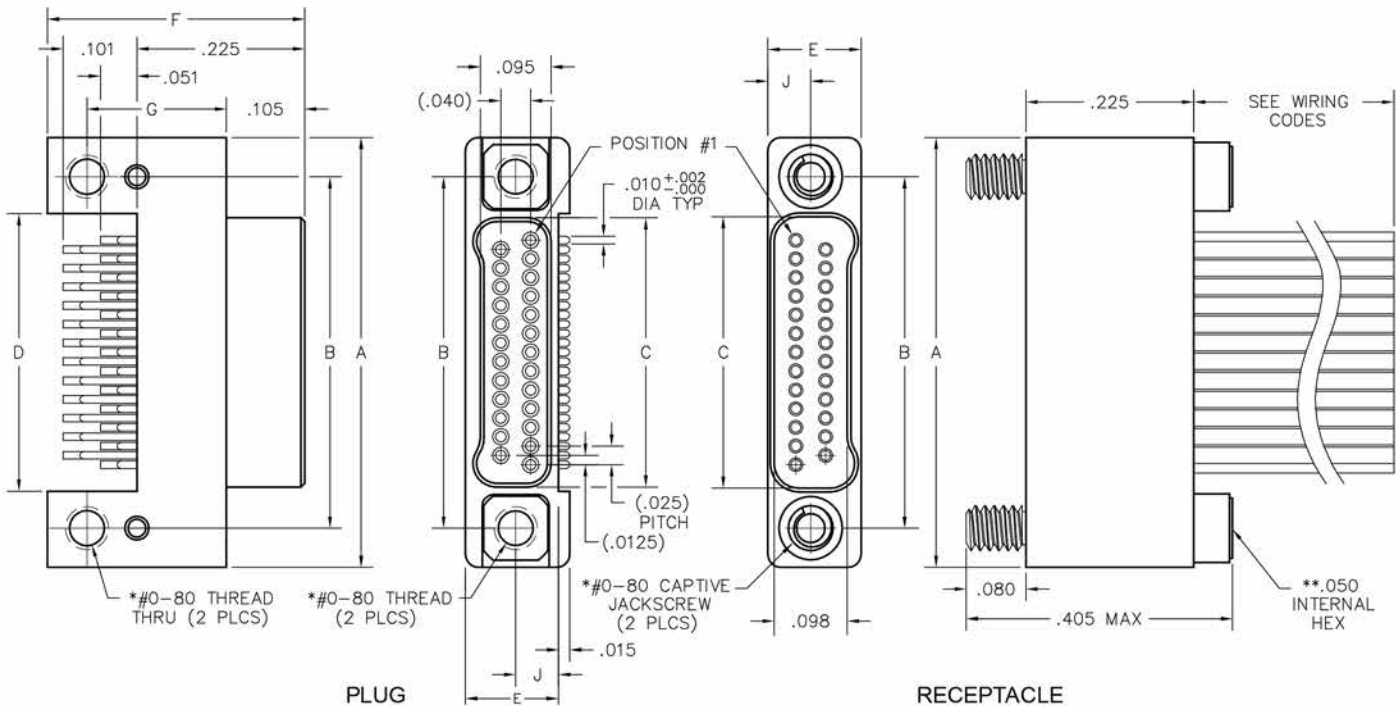
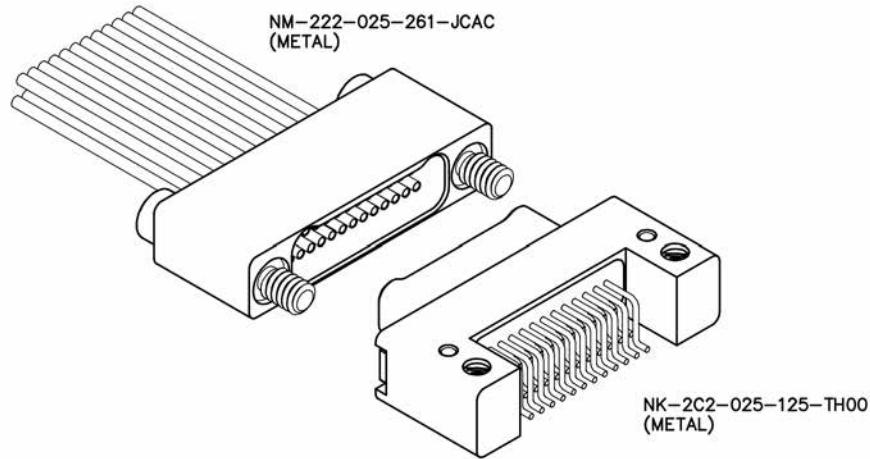

SIZE	DIMENSIONS				D	E	F	G	J	*HARDWARE
	A	B	PLUG	RCPT						
9	.375	.270	.160	.163	.170					
15	.450	.345	.235	.238	.245					
21	.525	.420	.310	.313	.320					
25	.575	.470	.360	.363	.370					
31	.650	.545	.435	.438	.445	.125	.345	.187	.0575	#0-80 THREAD
37	.725	.620	.510	.513	.520					
51	.900	.795	.685	.688	.695					
65	1.075	.970	.860	.863	.870					
69	1.125	1.020	.910	.913	.920					
85	1.377	1.246	1.110	1.113	1.120	.150	.375	.205	.0700	#2-56 THREAD
91	1.452	1.321	1.185	1.188	1.195					

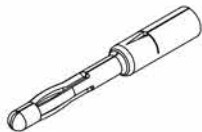

PIN CONTACT
3 TINE SPRING MEMBER, CRIMP

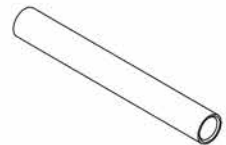

SOCKET CONTACT
DRAWN TUBE, CRIMP

* = #2-56 UNC THREAD ON 85 POSITION CONNECTORS.
 ** = 1/16" HEX ON 85 POSITION CONNECTORS. HEX MEASUREMENTS
 TAKEN ACROSS THE FLATS.